

3151A Water Valve

and EML100 Actuator

Applications

The 3151A Water Valve/EML100 Actuator assembly is used as part of a gas-turbine nitrous oxide emission-reduction system. The unit meters water into an industrial gas turbine's combustion chamber, lowering combustion temperature. This assembly is designed to be used with the Woodward EM Digital Driver.

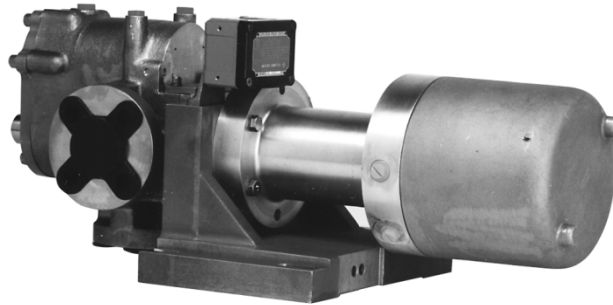

Description

3151A Water Valve

The 3151A Water Valve is intended for use with high-pressure centrifugal-type pumps and provides metered bypass flow for pump-stability and heat-balance considerations.

The water valve is primarily constructed of stainless steel. A replaceable, hardened, stainless-steel sleeve is located in the drain flange area of the valve housing, and protects the housing from cavitation damage. The sleeve can be rotated in one-quarter turn increments, or it can be replaced, to extend valve life when used in severe conditions.

Ceramic is used on metering valve and regulator valve parts to prevent galling and to resist erosion in an area subjected to high-velocity water streams.

These design features make the 3151A Water Valve highly resistant to erosion, corrosion, and cavitation.

The Water Valve is designed to meter up to 250 L/min (66 US gal/min) with input pressures from 2413 to 10 342 kPa (350 to 1500 psig). The minimum flow is 3.8 L/min (1 US gal/min), dependent on inlet pressure.

Flow accuracy is 5.0% of point or 0.5% of maximum flow, whichever value is greater.

Standard seal material allows operation with water temperatures up to 66 °C (150 °F). The minimum operating temperature is 0 °C (32 °F).

EML100 Actuator

The EML100 Actuator consists of a high performance brushless servomotor and a precision planetary gearbox with two resolver type shaft position sensors. The use of a high efficiency gearbox facilitates high servo system bandwidth. One resolver provides motor rotor position feedback and the other resolver(s) provides accurate output shaft position feedback. The gear train has a slip clutch to allow full speed impact into the rigid mechanical stops without damage.

The EM Driver controls the position of the EML100 actuator and water valve. Demand to the EM Driver is provided by a separate turbine control. The control may be calibrated so that the water valve closely follows the fuel-flow schedule to prevent unwanted water insertion during turbine load swings.

- All-electric water injection solution
- Used in gas-turbine nitrous oxide emission-reduction systems
- Fast response—accurate control
- Resists cavitation, erosion, and corrosion
- Models are available with certification for North American Hazardous Locations
- Models are available compliant with the applicable CE Directives: ATEX, PED, and Machinery

Features

- The water-valve assembly is a field proven design that provides a long service life.
- Woodward's 3151A Water Valve has a resistance to cavitation, corrosion, and erosion surpassing that of similar valves.
- The water valve achieves its high degree of reliability through the use of ceramic technology, hardened stainless steel parts, and a spool-type metering valve.
- The valve housing is made of stainless steel to resist corrosion. A specially designed, cavitation resistant, hardened, stainless-steel sleeve is used in the bypass port area—an area subject to cavitation.
- Water lacks lubricity, and ceramic technology is used on the metering spool to prevent galling of moving parts. Also, the ceramic is highly resistant to erosion caused by high-velocity water streams in the spool area.

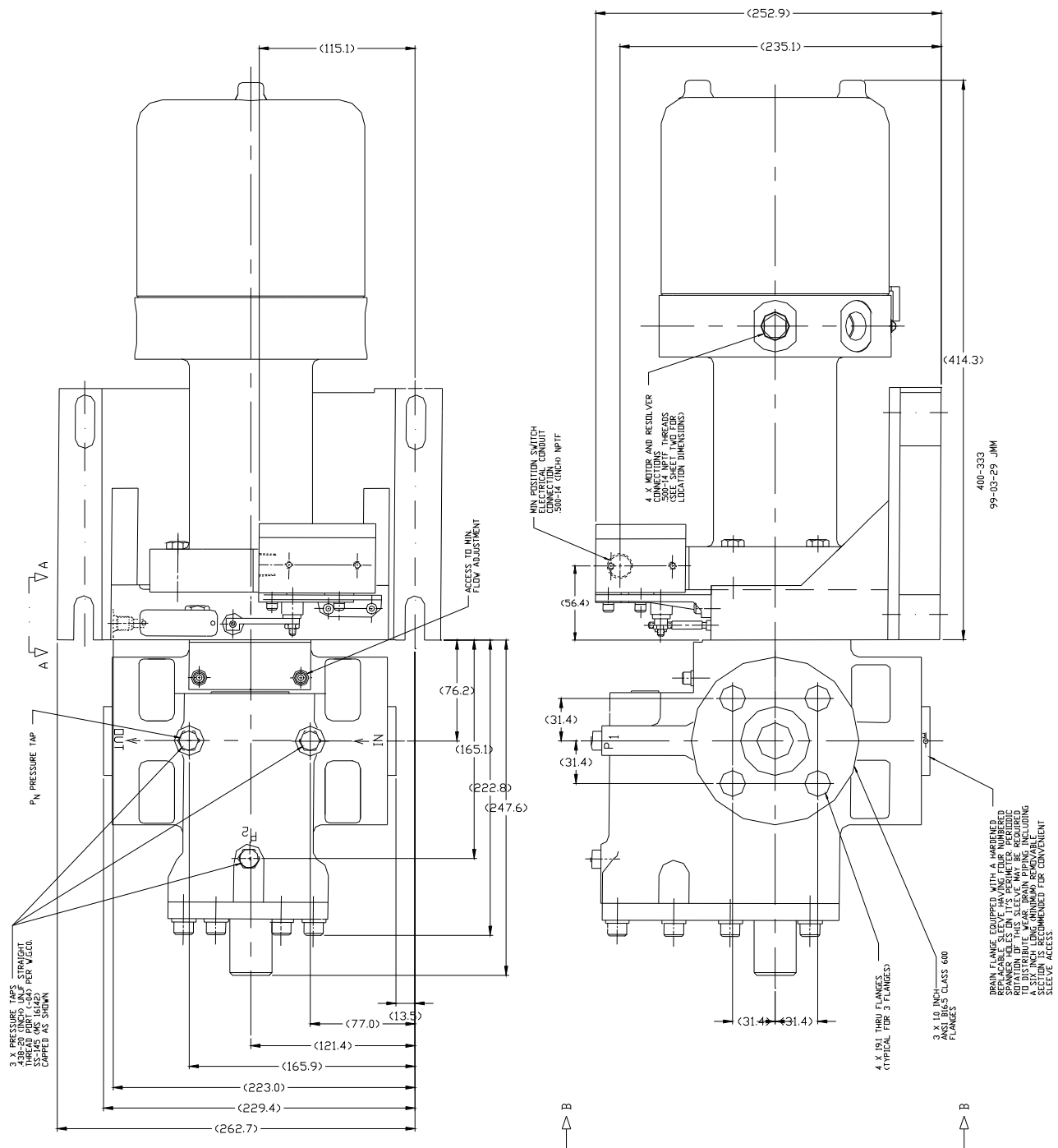

Outline Drawing
(Do not use for construction)

Operation

The actuator operates proportionally with an electronic control. The water valve/actuator assembly is designed to meter water to a gas turbine as established by a predetermined flow versus valve position schedule. This function is accomplished by a variable-area-metering valve and a single-stage, throttling, delta-P regulator piston.

The variable-area-metering valve consists of a set of contoured ports located at one end of the metering sleeve. The opening of these ports is determined by the position of the metering-valve plunger controlled by the actuator. The single-stage regulator piston senses and controls the pressure drop across the metering ports so flow is unaffected by variations in valve inlet or discharge pressures.

Specifications

3151A WATER VALVE

Minimum Flow

3.8 L/min (1 US gal/min)

Maximum Flow

250 L/min (66 US gal/min)

Water Pump Type

High pressure centrifugal

Minimum Supply Pressure

2413 kPa (350 psig)

Maximum Supply Pressure

10 342 kPa (1500 psig)

Maximum Bypass Pressure

345 kPa (50 psig)

Water Filtration

10 µm nominal

20 µm absolute

Degree-of-Flow Accuracy

Flow accuracy is either 5% of point or 0.5% of maximum flow—whichever is greater

Supply Temperature

66 °C (150°F) maximum, 0 °C (32 °F) minimum with standard seal material

EML100 ACTUATOR

Slew Time

150 milliseconds

(10%–90% position on a 2–98% step)

Bandwidth

Greater than 6 Hz at –6 dB

ENVIRONMENT

Ambient Temperature

–40 to +125 °C (–40 to +257 °F)

Vibration

US MIL-STD-810C, Method 514.2, category b.1, figure 514.2-II curve J (5 g's max. 5-2000 Hz)

Shock

US MIL-STD-810C, Method 516.2, half sine shock. Basic design-ground (20 g's for 11ms)

MTBO

50 000 hours

MTBF

100 000 hours

ELECTRICAL

The EML100 actuator is designed to be used with the Woodward EM Digital Driver. See manual 26159 for additional details.

Electrical Motor Ratings

Motor Voltage 28 Vdc nominal

Motor Current 37 A max phase current with an exponential decay and a time constant of 2.5 s to a maximum continuous phase current of 14.7 A

INSTALLATION

See outline drawing for other information.

Conduit connections

Quantity 4, 0.500-14 NPTF female connections.

External Ground

#8, 0.164-32 UNF female thread

Regulatory Compliance

European Compliance for CE Marking:

These listings are limited only to those units bearing the CE Marking.

ATEX—Potentially Explosive Atmospheres Directive:

Declared to 94/9/EEC COUNCIL DIRECTIVE of 23 March 1994 on the approximation of the laws of the Member States concerning equipment and protective systems intended for use in potentially explosive atmospheres. Zone 1, Category 2, Group II G, EEx d IIB T3 X

This suitability is the result of ATEX compliance of the individual components:

EML100 Actuator per LCIE 01ATEX6033 X

Note—3151A Water Valve/EML 100 Actuator assemblies incorporating the minimum position switch are not suitable for use in an ATEX environment.

Other European Compliance:

Compliance with the following European Directives or standards does not qualify this product for application of the CE Marking:

EMC Directive:

Not applicable to this product. Electromagnetically passive devices are excluded from the scope of the 89/336/EEC Directive.

Machinery Directive:

Compliant as a component with 98/37/EC COUNCIL DIRECTIVE of 23 July 1998 on the approximation of the laws of the Member States relating to machinery.

Pressure Equipment Directive:

Compliant as “SEP” per Article 3.3 to Pressure Equipment Directive 97/23/EC of 29 May 1997 on the approximation of the laws of the Member States concerning pressure equipment.

North American Compliance:

Suitability for use in North American Hazardous Locations is the result of compliance of the individual components:

EML100 Actuator:

CSA Certified for Class I, Division 1, Groups C & D; Class I, Division 2, Groups B, C, D, T3C at 125 °C Ambient. For use in Canada and the United States.

Minimum Position Switch:

CSA Certified for Class I, Division 1, Groups C & D. For use in Canada.

UL Listed for Class I, Division 1, Groups C & D. For use in the United States.

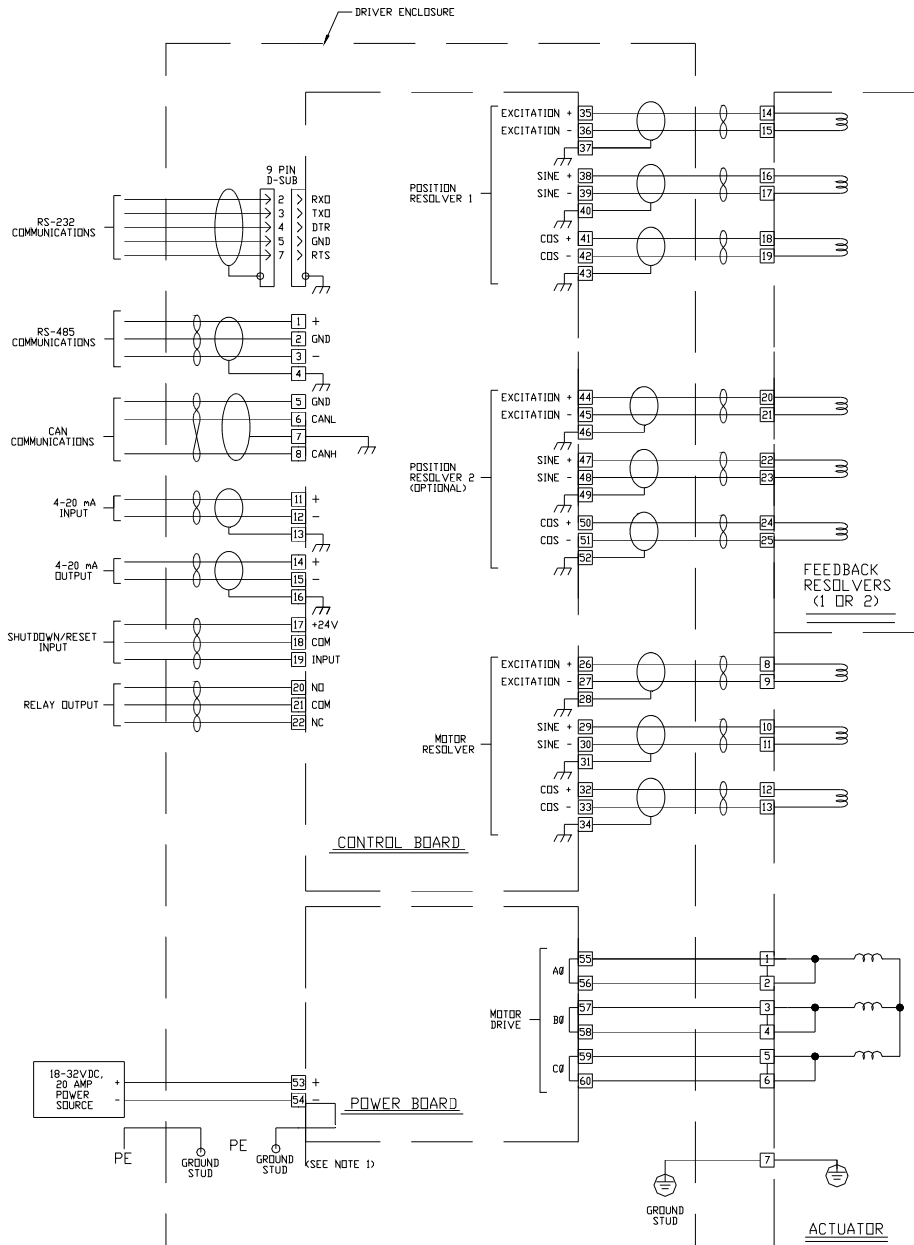

NOTES:
 1. AN OPTIONAL GROUND STUD IS PROVIDED FOR USE WITH AN UNGROUNDED POWER SOURCE.
 400-332
 99-03-23 JMM

Wiring Diagram



PO Box 1519, Fort Collins CO, USA 80522-1519
 1000 East Drake Road, Fort Collins CO 80525
 Tel.: +1 (970) 482-5811 ♦ Fax: +1 (970) 498-3058
www.woodward.com

Distributors & Service

Woodward has an international network of distributors and service facilities. For your nearest representative, call the Fort Collins plant or see the Worldwide Directory on our website.

This document is distributed for informational purposes only. It is not to be construed as creating or becoming part of any Woodward contractual or warranty obligation unless expressly stated in a written sales contract.

© Woodward 1999, All Rights Reserved

For more information contact: